

GO FOR IT



www.talaria.cn

Owner's-Manual

STING
P10



GO FOR IT

TALARIA POWER TECH

Contents

Introduction	01
An Important Message from Talaria.....	01
About This Manual.....	02
Transporting.....	03
Serial Numbers	04
Product Serial Number (SN)	04
SN Breakdown.....	05
Motor Serial Number.....	06
Safety Information	07
Useful Information for Safe Riding.....	07
Anti-Theft Alarm Information.....	08
Location of Important Labels.....	09
Controls and Components	10
Top View.....	10
Left Side View.....	11
Right Side View.....	12
Dash Overview.....	13
Starting and Operating	17
Pre-Ride Inspection.....	17
Riding Operating.....	18
Front Fork Adjustment.....	20

Rear Shock Absorber Adjustment.....	22
Charging and Battery information	23
Battery Charge/Discharge Connection Definition	23
Battery Charging and Charger Usage.....	25
Remove the Battery.....	27
Fit the Battery.....	28
Precaution for High Voltage Electrical Components	29
Malfunction Inspection and Troubleshooting	30
General Troubleshooting.....	30
Dash Error Codes, Failures and Troubleshooting	31
Maintaining Your Electric Bike	35
Owner's Responsibilities.....	35
Scheduled Maintenance.....	36
Electrical diagram	45
Technical Specification.....	46
Service and Maintenance Record Card	47
Warranty Description.....	47
Maintenance Schedule.....	48
Maintenance Guide.....	52
Maintenance Record Card	53
Customer Information Card.....	54

An Important Message from Talaria

Congratulations and thank you for purchasing the 2024 Talaria STING Pro electric bike! We welcome you to the community of Talaria Electric Bike riders. This manual is designed to provide you with a better understanding of the operation, inspection, and basic maintenance requirements of this electric bike.

Talaria continually seeks advancements in product design and quality. Therefore, this manual contains the most current product information available at the time of printing. Because of this, your electric bike may differ from the information supplied in this Owner's Manual. No legal claims can be made on the basis of data in this manual. When it comes time to sell your Talaria STING Pro, please ensure that this manual stays with the electric bike. It is an important part of the electric bike. If you have any questions concerning the operation or maintenance of your electric bike, please contact Talaria at support@talaria.cn

For 24-hour updates and additional information about your electric bike, visit the Talaria's official website:
<http://www.talaria.cn>

01

About This Manual

This manual covers the standard features, operations, malfunction inspections and warranty for Talaria STING Pro electric bikes.

Talaria STING Pro: All Terrain

Wire Wheels

19-inch Diameter Front Wheel

19-inch Diameter Rear Wheel

Knobby Tires

Locating and Referencing Information

The locate information about the electric bike is included in the specific parts of this manual. Please read this manual carefully before you ride or maintain this electric bike.

The terms “right” or “left” refer to the rider's right or left when sitting on the electric bike.

02

Transporting

It is recommended that the bike be tied-down using ratchet straps while it is being transported. Place the ratchet straps around a frame contact point. Soft straps must be used to reduce scratches or other damage. Use two ratchet straps in the front and two in the rear. The tie down straps should be at a 45° angle from the bike. Follow the manufacturer's instructions for the ratchet straps you are using.

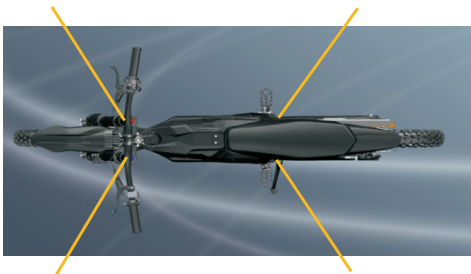

Caution

If it's indeed to lay down the electric bike to transport, please close the gearbox breather tube clamp to prevent the gear oil to flow out. And before riding, please don't forget to open the gearbox breather tube clamp. Otherwise, when the gearbox inner temperature rise, the air pressure might force the gear oil splash out!

03

Product Serial Number (SN)

The SN is a 15-digit number stamped on the right side of the frame's head tube. Do not alter or remove this number as it is the unique identifier for your bike

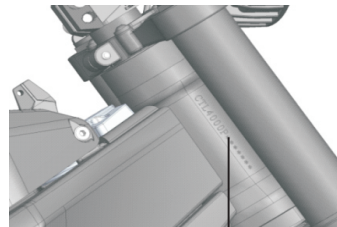

SN

04

VIN Breakdown

The following breakdown of the SN will help you to understand the significance of each digit or character in case you need to reference it when contacting Talaria or ordering parts.

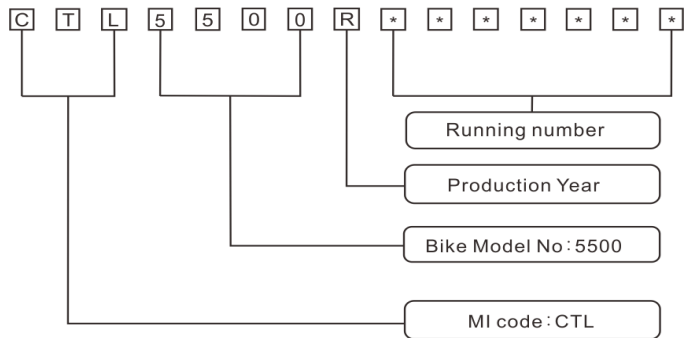

05

Motor Serial Number

The motor serial number is stamped on the left-hand side of the motor housing.

☆ 159ZW7240413NA ☆

And the Second row is the Talaria internal control number: Internal 6 – Digit Model Number + Manufacturing Date (YY/MM) + 1 – Digit Factory Identify Number + 4 – Digit Running Number:

Example: ☆ TL5500-24070210107 ☆

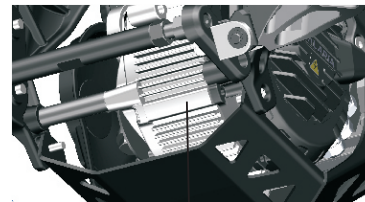

Motor Number

06

Useful Information for Safe Riding

This manual contains the word WARNING to indicate something that could hurt you or others. It also contains the word CAUTION to indicate things that could damage your electric bike.

WARNING!

Please read this manual carefully and completely before operating this electric bike. Do not attempt to operate this electric bike until you have attained adequate knowledge of its controls and operating features, and until you have been trained in safe and proper riding techniques. Regular inspections and proper maintenance, along with good riding skills, help you safely enjoy the capabilities and the reliability of this electric bike. Disregarding the aforementioned, however, may render the warranty invalid.



This symbol is located in various locations on the bike to inform you that exposure to high voltage can cause shock, burns and even death. The high voltage components on the electric bike should be serviced only by technicians with special training. High voltage cable or wiring has an orange covering. Do not probe, tamper with, cut, or modify high voltage cable or wiring.

Anti-Theft Alarm Information

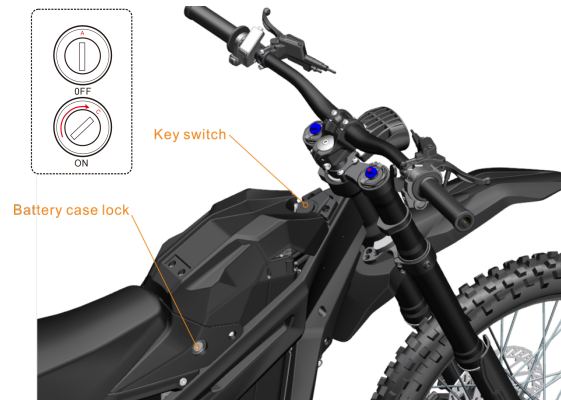

Key Switch: Turn the key clockwise, and the whole electric bike is powered on; turn it anticlockwise, and the whole electric bike is powered off, and then remove the key.

Battery Case Lock: Insert the key and turn it anticlockwise, and then open the Battery Case Lock.

Location of Important Labels

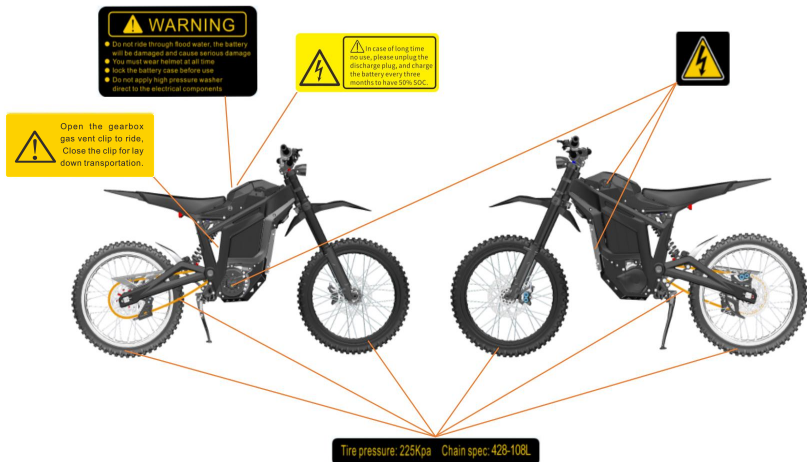

Top View

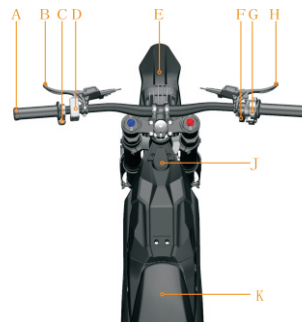

- A: L. Handlebar Grip
- B: Rr. Brake Lever
- C: Switch Assy.
- D: Dash
- E: Fr. Fender
- F: Regen Switch
- G: Throttle
- H: Fr. Brake Lever
- I: R. Handlebar Grip
- J: Key Switch
- K: Seat

Caution

The picture is for reference only, and the actual product may differ from above picture for any necessary improvements.
 The Regen Switch can only be used when the SOC is less than 90% and select the Regen level 1. Press the Regen Switch harder or lighter for stronger or weaker Regen. When you select Regen Level 2, 3 or 4, the Regen Switch will not work, and the Regen will work as per each level's setting.



Left Side View

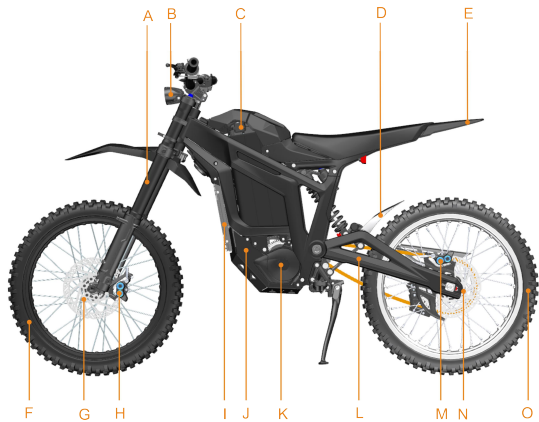

- A: Fr. Fork
- B: Headlight
- C: Battery Charging Interface
- D: Rr. Wheel Fender
- E: Rr. Fender
- F: Fr. Wheel
- G: Fr. Brake Disc
- H: Fr. Brake Caliper
- I: Controller
- J: Gearbox Guard
- K: Gearbox Cover
- L: Rr. Fork
- M: Rr. Brake Caliper
- N: Rr. Brake Disc
- O: Rr. Wheel

The picture is for reference only, and the actual product may differ from above picture for any necessary improvements.

Right Side View



- A: Upper Chain Guide
- B: Tail Lamp
- C: Rr. Shock Absorber
- D: Battery Case Cover
- E: Frame
- F: Sprocket
- G: Lower Chain Guide
- H: Chain
- I: Side Kickstand
- J: Motor
- K: Horn

The picture is for reference only, and the actual product may differ from above picture for any necessary improvements.

Dash Overview

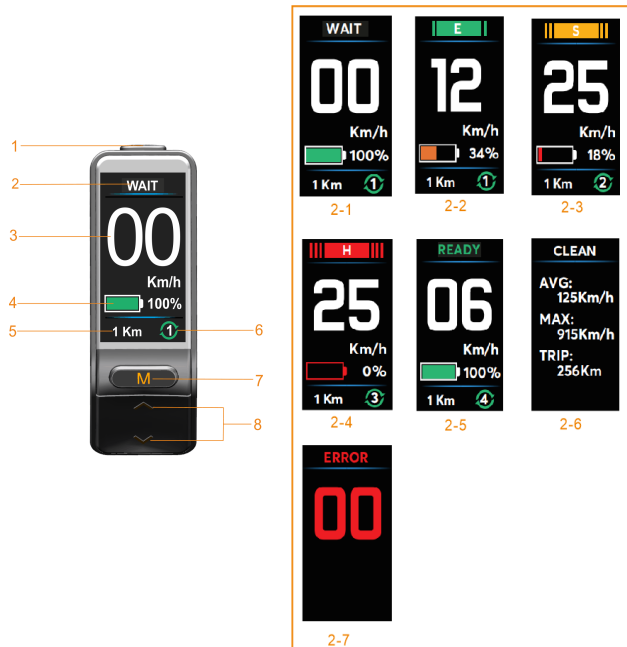

1. Setting: Keep pressing Setting to enter into the setting interface. (It's not workable during riding.)

2. Status:

2-1 WAIT: WAIT means your electric bike is not ready to ride. Need the side kickstand to be swung back, loosen the brake lever, and press the START button to have your electric bike to be ready to ride.

2-2 E: ECO mode, with limited power out-put for the longest riding distance per charge. It's eco-friendly for beginners.

2-3 S: SPORT mode, with continuously surgent power output for off-road and trail riding. It will bring the skilled riders an amazing experience.

2-4 H: HYPER mode, with extremely hyper power output for aggressive racing riding. It's only for PRO riders.

Warning!

H (HYPER mode) is only for PRO Riders. It's not for beginners. For your safety, we strongly suggested that if you are not PRO riders, or before you attained adequate knowledge of its controls and operating features, please do not attempt to ride this electric bike with H Mode. PRO safety riding gears are required to be equipped!

2-5 READY: When the dash indicates READY, then, the electric bike is ready to ride. Twist the throttle slowly and stably to start the electric bike.

2-6 CLEAN: Pressing M button for 3 seconds to reset the AVG speed, MAX speed and Trip.

2-7 ERROR: Display the error code to remind the rider (Please refer to error codes from page 31).

3. Speedometer: Display the real-time speed.

4. SOC Indicator: Display the real-time remaining battery.

5. Odometer: Display the trip mileage. Pressing odometer will clear the trip mileage to be zero. When the odometer reaches to 999km, overflow to zero automatically.

6. Regen Levels Indicator: Display the real-time regen level. (Regen level 1, 2, 3, 4 can be set. When level 1 is chosen, and the SOC is less than 90%, can use the Regen Switch to control the Regen)

- 7. **M Button:** When the electric bike is powered on, keep pressing Setting to enter into the setting interface. After the setting is done, press M to save the setting. M is also the shortcut button to choose E/S/H riding modes when the dash doesn't enter into the setting interface.
- 8. **SEL UP/SEL DOWN:** When the electric bike is powered on, keep pressing Setting to enter into the setting interface, then, press SEL UP/SEL DOWN to choose the setting. SEL UP/SEL DOWN are also the shortcut buttons to choose the regen levels when the dash doesn't enter into the setting interface.



A: EXIT: Exit the setting interface. Press the SEL Buttons to select EXIT, and then, press M Button to exit the setting interface.

B: Data: Display the riding data. Press SEL Buttons to choose the DATA. Then, press the M Button to enter into the data display interface. The data display includes AVG energy, max speed, AVG Speed, boot time, ODO.

C: Unit Selection: Press SEL Buttons to choose the UNIT. Then, press M Button to enter into the UNIT setting interface. Press SEL Buttons again to choose Metric or Imperial, then, press M Button to save the setting.

D: Wheel: Wheel diameter setting. Press SEL Buttons to choose the Wheel for 14inch, 16inch, 17inch, 18inch and 19inch. Then, press M Button to enter into the Wheel setting interface. Press SEL Buttons again to choose the correct wheel diameter, then, press M Button to save the setting.

Notice: The wheel diameter refers to the rear driving wheel. If you choose the wrong wheel diameter, your bike will still run with no problems. But the Speedometer will display the incorrect real-time speed.

E: GR: Gear ratio selection. Press SEL Buttons to choose the GR. Then, press M Button to enter into the GR setting interface. Press SEL Buttons again to choose the correct gear ratio, then, press M Button to save the setting. (1:4.7 for 25T, 1:6.9 for 36T, 1:7.5 for 40T, 1:8.4 for 44T, 1:9.1 for 48T, 1:9.5 for 50T, 1:11 for 58T)

F: BATTERY: Display the battery information. Press SEL Buttons to choose the BATTERY. Then, press M Button to enter into the battery data display interface. Battery voltage, capacity, and charged times will be displayed.

G: Match: Press SEL Buttons to choose the MATCH. Then, press M Button to enter into the MATCH setting interface. When the electric bike status is "WAIT", and the side kickstand is swung back. Meanwhile, the rear wheel is supposed to be off the ground. Then, the electric bike will have a small move, and after that, it will show the match is successful or failed.

Remarks: The offset of the magnetic encoder's electrical angle is possible to make the motor get reverse rotation. The MATCH function will self-adapt the offset, and prevent the motor reverse rotation happen. Each motor will be rigidly matched before the delivery. In case, it's necessary to do the MATCH, please inquire the dealer who sold the electric bike to you. Moreover, if the fault code "E33" appears during the riding process, please refer to the above "motor match" to eliminate the fault.

H: HMI info

a: ECM motor software\hardware version number.

b: BMS battery software\hardware version number.

c: ICM dash software\hardware version number.

d: T-BOX version number (It only shows when T-BOX is installed) .

Pre-Ride Inspection

Before riding your Talaria STING PRO electric bike, check the following to make sure the electric bike is secure and intact:

- **Battery:** Make sure the charge indicator on the dash is indicating a charged battery. We suggest you recharge before use. Always keep the charger available.
- **Brake:** Squeeze the left and right brake levers individually while pushing the bike to see if it rolls. You should be able to lock-up the wheels completely by applying the brakes.
- **Throttle:** Make sure the electric bike is power off, apply the throttle and release to verify that the throttle is smooth and returns correctly.
- **Tires:** Check both tires for condition and tread depth. Check cold tire pressure frequently. Check for damage and alignment. Maintain correct tire pressure as specified to be both front and rear tire 225KPa. Replace the tires when the tread height is worn 2/3 or more.
- **Electric system:** Check for correct function of the headlight, and the tail lamp.

Riding Operation

• Starting

1. Insert the key into the key switch, rotate to the right to the ON position, and then check the switches, dash and horns for normal function, squeeze the front and rear brake lever, and check whether the braking function is normal.
2. Motor start: After finishing the above step, swing back the kickstand (the dash indicates WAIT), sit on the electric bike steadily, and press the START button on the throttle. The dash indicates READY, then, the electric bike is ready to ride (READY and the current riding mode E/H/S are displayed alternatively). Twist the throttle slowly and stably to start the electric bike. The electric bike is equipped with the function of power-cut protection when the kickstand is standing the electric bike, in this case, the motor will not run.

• Speed control

Twist the throttle in a counter-clockwise rotation to energize the motor and start the bike in a forward direction. Twist the throttle in a clockwise rotation to de-energize the motor. Release the throttle and it snaps back to the closed position, the motor stop working.

Caution: Progressive use of the throttle is not recommended; aggressive use will cause malfunction or even damage the throttle.

• Braking

On the right handlebar is the hand operated brake lever for front brake. The brake lever controls the front brake when the lever is squeezed. On the left handlebar is the hand operated brake lever for rear brake. The brake lever controls the rear brake when the lever is squeezed. When braking, the throttle should be in the closed position.

WARNING! You need to control the brake level squeeze force accordingly, and if you apply the front or rear brake hard enough, it is possible to lock the wheels. This could cause you to lose control of the electric bike and could lead to serious injury or death. Progressive use of the brakes should bring the electric bike to a complete stop without locking the wheels. Your Talaria Sting PRO electric bike is a light-weight performance product and therefore practice is strongly recommended to perfect safe emergency stops.

- **Precautions For Ridiing**

1. In the premise of ensuring safety, ride smoothly as far as possible, and avoid sudden acceleration or deceleration, so as to save electricity, protect components, and improve the endurance mileage and electric bike service life.
2. Sideslip may easily happen on wet roads in rainy or snowy days. Please stay focus and be responsive. Brake function may be slightly compromised after the electric bike is washed or ridden through puddles. In this case, ride slowly and be careful. Brake gently for several times until the brake goes back to work normally.
3. Please avoid riding in heavy rain or water. If the water level is higher than the wheel center, it may adversely affect the motor and brake. The electric bike can be used in rainy and snowy days, and long-time deep wading must be avoided. Once the water depth exceeds the height of controller and other electrical components, damages may be caused to the electrical components.
4. The kickstand is only used for standing the electric bike. Do not sit on the bike when the kickstand stands the electric bike, or it may be damaged.
5. Do not park the bike at a place where the ground is tilted or soft, or it may cause the electric bike to fall over.
6. The electric bike contains a lot of electrical components. Please avoid long-time exposure to rain or using high pressure washer to rinse the parts with electrical components.

- **Parking**

1. Pay attention to your back and slow down to approach the parking site.
2. Use the brake to park the electric bike, reset the throttle, turn OFF the Key Switch and remove the key after the electric bike stopped.
3. After parking, swing out the kickstand to stand the electric bike. Make sure you have turn off the electric bike, and well lock battery case locks before leave and take the key with you.

Fr. Fork Adjustment

Compression damping adjuster A (turn the adjuster clockwise to increase compression damping, and turn the adjuster counterclockwise to decrease compression damping).
Rebound damping adjuster B (turn the adjuster clockwise to slow down the rebound speed, and turn the adjuster counterclockwise to speed up the rebound speed).

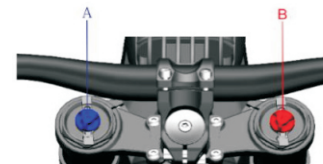

Spring preload adjuster C (turn the adjuster clockwise to increase the spring preload, and turn the adjuster counterclockwise to decrease the spring preload)

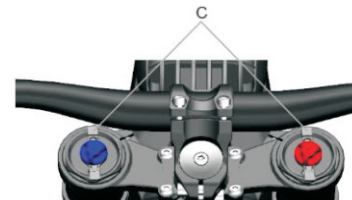

Caution

The Fr. fork and Rr. shock absorber play the buffer role, they are important to enable your riding to be stable and comfortable, even there are bumps on the road.

To solve the front fork and rear shock absorber supply shortage. Talaria will mix use Talaria and DNM Fr. forks and Rr. shock absorbers. All these Fr. Forks and Rr. shock absorbers have passed Talaria's strict performance tests.

The adjustments and maintenances for Fr. forks and Rr. shock absorbers differ among the brands. Please follow the user's manual, which is shipped together with the electric bike.

Rr. Shock Absorber Adjustment

Compression damping adjuster A (turn the adjuster clockwise to increase compression damping, and turn the adjuster counterclockwise to decrease the compression damping)

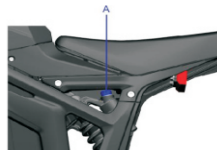

Rebound damping adjuster B (turn the adjuster clockwise to slow down the rebound speed, and turn the adjuster counterclockwise to speed up the rebound speed)



Spring preload adjuster C (turn the adjuster clockwise to increase the spring preload, and turn the adjuster counterclockwise to decrease the spring preload)



Battery Charge/Discharge Connection Definition

Talaria Sting Pro uses high-performance and high-rate lithium battery with a safe voltage of 72V. The battery can be used at the temperature of -20°C - 60°C , optimally at 10°C - 30°C . Too low or too high temperature will adversely affect the performance and lifetime of the battery, so please do not use it at a temperature beyond this range.

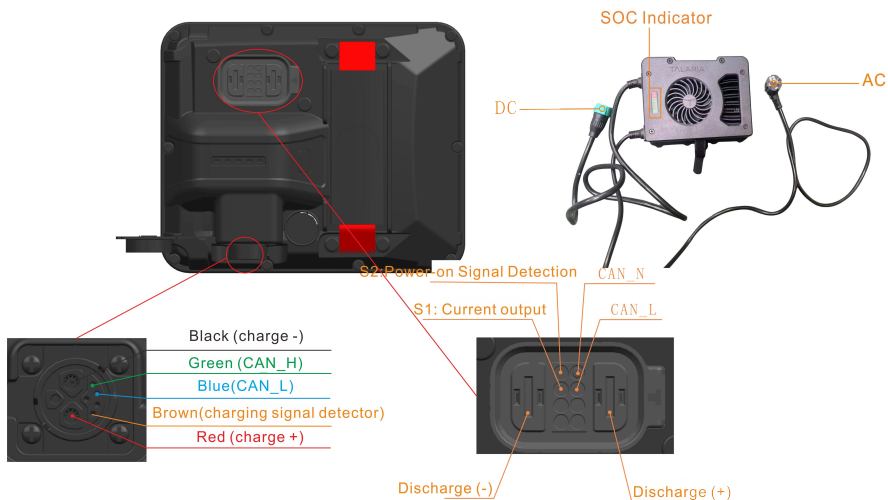

Warning!

1. Do not charge the battery under 0°C , otherwise it will damage the battery. Please wait until the battery temperature rises.
2. Too low temperature will affect the battery performance, which contributes to a slight drop of endurance mileage. It will go back to normal when the temperature rises.
3. The battery is provided with well-improved protection function, saving itself from the damage causing of overcharge. However, deep discharge during usage will affect the battery performance. Please charge the battery promptly in the case of low power.
4. Please charge the battery frequently. The lithium battery used in this electric bike operates with no memory effect. So, it can be charged at any time, which is also favorable for the battery to stay healthy.
5. In case of long-term storage, charge the battery to about 50%, then, disconnect the discharge plug. Charge the battery at least once every 3 months to prevent it from losing activity and avoid compromised performance. Otherwise, it's the user's responsibility for any battery issues caused by not charge the battery in time.
6. It is strictly prohibited for users to disassemble the battery by themselves to avoid damage and danger.
7. It's not allowed to use non-factory stock chargers to charge the battery.
8. Do not expose battery to high temperature (direct sunlight) for a long time, otherwise the battery may overheat or function failure and shorten the life.

Battery Charging and Charger Usage

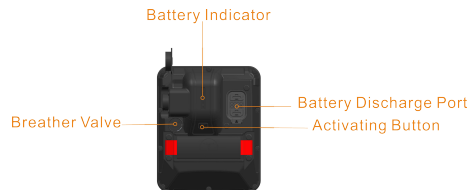

1. The electric bike uses a customized lithium-ion battery charger. Do not use other chargers, or it may cause battery damage or danger.
2. Check whether the input voltage of the charger is consistent with the grid voltage AC110V/AC230V.
3. The battery can be charged on your electric bike through the Charging Interface, or you can also get out the battery to charge directly.
4. When charging, the charger and battery charging interface must be connected properly before connecting the charger to the grid socket. After charging, disconnect the charger and grid socket first, and then disconnect the charger and battery after the indicator light goes out. If you plug the charger into the grid socket first, and then, please be sure to connect the charger and battery charging interface properly within 3 seconds. Otherwise, the battery cannot be detected, the charger will run the protection setting, and automatically shut down!
5. When the red indicator of the charger flashes, it indicates that charging is ongoing. When the green indicator of the charger is on, it indicates that the battery is fully charged. Usually, the charging time will be 2~4 hours to fully charge the battery, it will depend on the SOC of the battery and the user's choice of charger.

6. The charger will shut down automatically after the battery is fully charged. But it's strongly suggested that always avoid connecting the charger to the grid socket for a long time, which shall not exceed 6 hours.
7. It is strictly prohibited for untrained people to disassemble the battery, otherwise, may lead to battery damage and danger.
8. When the battery enters inactive status, it can be activated with the activating button or by connecting the charger.

----- Charging precaution -----

1. When charging, please park your electric bike or put battery in a safe place out of the reach of children.
2. The internal temperature for the battery which has just been discharged is high. Do not charge it immediately. It's recommended to charge the battery after ventilation and heat dissipation for 30 minutes.
3. Avoid using the battery immediately after it is fully charged. Let it stand for 10 minutes before using.
4. It is strictly prohibited to cover the charger with any object when using it. This charger is for indoor use. Please use it in a dry and well-ventilated place.
5. In case you find peculiar smell or high temperature during charging, or the battery is not fully charged after charging for a long time, please stop charging immediately and send it to the local dealer for maintenance.

Remove the Battery



① Press the battery case cover and turn the key counterclockwise to unlock the battery case cover simultaneously.

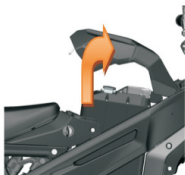

② Rotate the battery case cover clockwise.

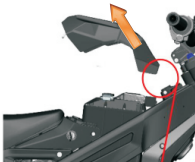

③ Remove the battery case



④ Press the discharge plug locker and disconnect the discharge plug.



⑤ Remove the battery.

Install the Battery



① Install the battery into the holder.



② Press the discharge plug locker and connect the discharge plug. Make sure the plug locker well locked.

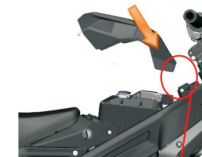

③ Well fit battery fixing device dropout on the pins.

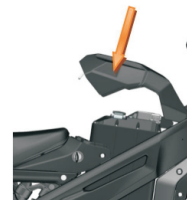

④ Press the battery case cover with proper pressure, and lock it.



Precautions for High Voltage Electrical Components

Your Sting Pro electric bike contains high voltage electrical components. These components are dangerous and can cause personal injury, severe burns, electric shock or even fatal injury unless appropriate preventive measures are taken.

Always follow the instructions on the label of each electrical component, which is very important for your safety.

Do not touch, attempt to remove or replace any high-voltage components, cables (identified by orange outer protection) or connectors. In the event of an accident with the electric bike, do not touch any high-voltage cable connector or assembly connected to the cable. In case of fire of the electric bike, use a carbon dioxide or class-D dry chemical fire extinguisher to put out the fire. After the fire is extinguished, please do not start the electric bike, and send it to the authorized dealer to repair.

Warning: Your electric bike works on high voltage. During and after the start-up and when your electric bike is powered off, the high voltage components may be too hot to touch by hand. Pay attention to high voltage and high temperature. Follow the label instructions everywhere on your electric bike.

Warning: The high-voltage components of the electric bike is maintenance-free to customers. Disassembly, removal or replacement of high-voltage components, cables or connectors may cause severe burns or electric shock, which may lead to severe injury or death. High-voltage cables are made in orange for easy identification (see response information in the latter section of this manual).

Remarks: All the electric bike have been carefully inspected before delivery. But there will inevitably be some technical problems even after inspection. The following information serves as a guide to help you identify the problem and repair it by yourself if possible. If you cannot solve the problem, please send it to an authorized dealer for solution.

General Troubleshooting

Failure	Possible Cause	Suggested Solution
vehicle cannot start	The battery is out of power. U, V and W wires on the motor are incorrectly or loosely connected.	Check whether the discharging plug is in contact with the battery and whether there is a pin distortion.
Charger doesn't work	No AC power supply.	Check whether the AC socket is powered. Check the fuse/voltage of the AC power supply.
Handlebars shake	The tire pressure is not enough	Inflate the tires with suggested tire pressure.
	Deformed front tire	Replace the front tires with the same tires supplied by the factory
	Worn Tire (tire tread is over worn)	Replace the tire(s) with same tire(s) provided by the factory

Dash Error Codes, Failures and Troubleshooting

Error Code	Failure	Suggested Solution
E01	Protection IC failure	Restarting
E02	Battery Cell disconnection	Restarting
E03	Unbalanced battery cell voltage	Restarting
E04	Measurement errors	/
E05	Storage error	Restarting
E06	Time display error	Restarting
E07	Discharge MOS error	Restarting
E08	Charge MOS error	Restarting
E09	Overcharge error	Restarting
E10	Level 1 over discharge error	Users are advised to charge in time.
E11	Level 2 over discharge error	Users are advised to charge in time.
E12	Level 1 over discharge current error	The error is removed automatically after 1min.
E13	Level 2 over discharge current error	Stop the over current discharge or control the discharge current less than 110A, or check whether there's the short circuit? If yes, eliminate the short circuit.
E14	Over charging-current error	1. Whether the power strip is used incorrectly 2, if the replacement of the matching charger can not be solved, please send after-sales maintenance
E15	Soft start failure error	Please power on and start the vehicle according to the instructions.
E16	Overtime pre-charge error	1.Replacement of the matching charger 2.If the replacement of the charger still can not solve the fault, please send to the after-sales maintenance.
E17	OS temperature sensor fault error	Restarting
E18	Cell temperature sensor fault error	Restarting

Error Code	Failure	Suggested Solution
E20	Battery charge over-temperature	Wait until the temperature protection is removed before riding or charging. It is advisable to use the vehicle according to the instructions
E21	Battery discharge low temperature error	Wait until the temperature protection is removed before riding or charging. It is advisable to use the vehicle according to the instructions
E22	Battery charge low temperature error	Wait until the temperature protection is removed before riding or charging. It is advisable to use the vehicle according to the instructions
E23	Battery discharge MOS over-temperature error	Wait until the temperature protection is removed before riding or charging. It is advisable to use the vehicle according to the instructions
E24	Battery discharge MOS over-temperature error	Wait until the temperature protection is removed before riding or charging. It is advisable to use the vehicle according to the instructions
E25	Soft-start circuit over-temperature error	Stop to ride the vehicle until the over-temperature protection unlocked.
E26	Storage error	Send the vehicle to the nearest dealer to repair.
E27	No error	/
E28	No error	/
E29	Level 3 over current error	Inspect and eliminate the short circuit.
E30	Level 4 over current error	Inspect and eliminate the short circuit.
E31	Setting error	Send the vehicle to the nearest dealer to repair.
E33	Controller phase wire over current error	1. Turn off the vehicle. Then, check whether the motor phase wire terminal got loose, or broken. And then, check whether the motor outlet phase sequence corresponds to the U / V / W on the controller. Finally, check whether the magnetic encoder output wire corresponds to the yellow, green and blue wires on the harness assy. 2. Check whether anything stuck the rear wheel.
E34	Controller busbar over current error	1. Turn off the vehicle. Then, check whether the motor phase wire terminal got loose, or broken. And then, check whether the motor outlet phase sequence corresponds to the U / V / W on the controller. Finally, check whether the magnetic encoder output wire corresponds to the yellow, green and blue wires on the harness assy. Check whether anything stuck the rear wheel.

Error Code	Failure	Suggested Solution
E35	Power tube error	Replace the controller assembly or send it to the local authorized dealer for maintenance
E36	Tip-over sensor error	1. Turn off the vehicle, make it stand still. 2. Restart the vehicle, and the fault is eliminated;
E37	Throttle error	1. Check the throttle connection is loose or broken. 2. Make sure the throttle return to the proper position before the start. 3. If the throttle connection is no problem, and throttler return to the proper position, still have the throttle error. Then, just replace a new throttle.
E38	Low voltage protection	It is recommended to charge in time.
E39	Over voltage protection	Please use Talaria's stock charger to charge the battery.
E40	Magnetic encoder error	Check whether the magnetic encoder got a poor contact or is broken? If yes, repair or replace it.
E41	Motor phase wire failure error	Turn off the vehicle. Then, check the whether the motor phase wire terminal got loose, or broken. And then, check whether the motor outlet phase sequence corresponds to the U / V / W on the controller. Finally, check whether the magnetic encoder output wire corresponds to the yellow, green and blue wires on the harness assy.
E42	Motor over-temperature error	It is recommended to use it after the temperature protection is removed, or check whether the motor encoder plug is loose.
E43	Motor temperature sensor error	It is recommended to use it after the temperature protection is removed, or check whether the motor encoder plug is loose.
E44	Controller Over-temperature error	Stop riding until the controller return to the normal temperature.
E45	Controller temperature sensor error	Stop riding until the controller return to the normal temperature.
E46	Current sensor error	Please send the vehicle to the nearest dealer to inspect and repair.
E47	Motor lack of phase error	1. Restart the bike. 2. Turn off the bike. Then, check the whether the motor phase wire terminal got loose, or broken. And then, check whether the motor outlet phase sequence corresponds to the U / V / W on the controller. Finally, check whether the magnetic encoder output wire corresponds to the yellow, green and blue wires on the harness assy.

Error Code	Failure	Suggested Solution
E48	Motor locked-rotor protection error	1. Turn off the key switch. Then, put the bike on a bench, to check whether the rear wheel can rotate normally, if anything stuck the rear wheel, please eliminate it. And please also check whether there are things stuck the motor, gearbox, chain and brake. If yes, please eliminate it. 2. Choose the right road condition to ride the bike.
E49	Communication error	Turn off the key switch. Then, check the all the CAN connections on the bike to see whether there's the loose or breaks. (Dash connection, controller connection, battery pack communication connection. These 3 positions have CAN connections). If there's the loose or breaks, just repair them, and re-start the bike, the error will be solved.
E50	Vehicle locking error	The problem can be resolved by riding the vehicle within the range of the electronic fence and then restarting it.

Owner's Responsibilities

Listed below are the responsibilities afforded to the owner:

- This Owner's Manual should be considered a permanent part of this electric bike and should remain with it even if the electric bike is subsequently sold.
- Perform routine care and maintenance of your electric bike as detailed in this Owner's Manual.
- Use only Talaria approved parts and Talaria Electric Bike accessories. Otherwise, will render the warranty invalid.
- The operator is responsible for learning and obeying all country, federal, state, and local laws governing the operations of an electric bike.
 - Always wear a regionally approved helmet, goggles, appropriate boots, and all other appropriate safety equipment when operating an electric bike.

Scheduled Maintenance

To prolong the lifetime of your electric bike and ensure a safe and comfortable riding, regular inspection and maintenance is recommended. If bike do not use for a long term, it should also be inspected regularly.

The first inspection and maintenance for a new electric bike should be done after running for 300KM.

Pay attention to safety when you inspect or maintain the electric bike.

Park the electric bike at an open and flat ground.

Any issues are found during the riding and need to be inspected, it's strongly suggested to find a safe ground to carry out the inspections, and pay attention to the surroundings.

Any issues found through the inspection should be eliminated before you ride the electric bike. If it is difficult to solve it by yourself, please send the bike to the nearest dealer for service.

Caution

The front and rear brakes are disc brakes. If the brake pads are severely worn, shall replace them in time.
Keep the disc brake system clean in daily use to avoid sand accumulation for a long time, especially oil stain.

Parts/Maintenance Items

Front Fork Inspection: Check the front fork for any bending, deformation, damages, looseness, oil leakage and other faults. Press the handlebar up and down to check for any abnormal sounds caused by front fork fault.

Brake Inspection:

1. Check whether the free clearance of the brake lever is within the specified range (15-30mm). If the measured result does not meet the requirement, it shall be adjusted.
2. When driving at low speed on a dry and flat road, use the front and rear brakes respectively to check whether the brakes work correctly

Inspection For Tire and Other Parts

1. Inspect the air pressure with a tire barometer when the tire is in normal temperature status.
2. Inspect the tire for any cracks, damages, foreign matters and abnormal wears.
3. Inspect whether the spokes are loose.
4. Inspect the tension of the chain.

Caution

Stones, glass, nails and other foreign matters on the ground will easily damage the tire as tire contact with the ground for a long-term. When riding, make sure to observe the road surface to avoid the places where the tire may be damaged. In addition, regularly check the tire for any obvious cracks and other damages, whether it has been penetrated by stones, glass and other foreign matters, and whether there are abnormal wears.

Inspection For Tire Tread Depth

Check the tire wear and the tread depth. Replace the tire if 2/3 of the tread are worn off. When the tire makes abnormal noise and swings during riding, please send the bike to the nearest dealer for inspection and maintenance. It is recommended to set the locking torque of the rear fork axle as 50-60N.m and the locking torque of rear axle nut as 45-55N.m. The locking torque of the front wheel axle is 15N.m.

Caution

Hold the brake lever tightly. If the brake still can't achieve the ideal braking function, check whether the brake disc is clean. If the problem is still not solved, send the bike to the nearest dealer for inspection and maintenance.

Fuse replacement

If the dash, horn, lamps and other parts still do not work after turning on the vehicle, it is probably because the fuse is broken. Turn off the vehicle before replacing the fuse.

1. Open the battery case cover and pull out the battery. Open the fuse box which is located in the front of the battery case.
2. Remove the broken fuse, install spare fuse, close the fuse box, install the battery and close and lock the battery case cover.

Caution

The fuse should be installed firmly. If it is loose, it may cause the fuse to heat up and results in other faults and hazards. Replace the fuse with those of the specified model and corresponding specification. If the fuse is out of specification, it may not have the function of fuse protection. If the new fuse is broken again in a short time, check for the causes other than the fuse. Avoid strong impact to the fuse with water flow.

Inspection for Brake Fluid Level

Check the front and rear brake fluid level via the view lens on the brake fluid reservoir. If the brake fluid level is low, brake fluid must be added. Open the reservoir cap to add specific brake fluid (JG3).

Caution

Before checking the brake fluid level, the electric bike should remain upright.

1. Remove the two M4 screws from the brake fluid reservoir cap. (Pictured below)
2. Add the specified brake fluid for disc brake. (JG3)
3. Check the sealing cover for any wears or damages, and make sure it's in the correct position.

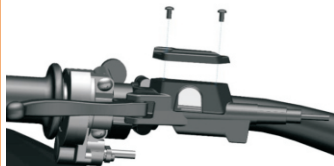

Warning!

Do not spill the brake fluid on the paint surface; otherwise, it may cause cracks on the surface of the paint parts. Before removing the brake fluid reservoir cap, be sure to place a clean rag under the brake fluid reservoir. At low brake fluid level, there may be brake pad wear or leakage of hydraulic system. Check the brake pads for wear and/or the hydraulic system for leakage before riding. Add the specified brake fluid (JG3) for disc brake. Do not use other kinds of brake fluid. Fixing the brake fluid reservoir and tighten the M4 screws. The tighten torque is 1-2N.m.

Inspection for brake pads

Check the brake pads and visually check the brakes by observing the remaining brake pad materials on both sides of the brake caliper.



Replace the brake pads when the free clearance of the brake lever exceeds the specified range (15–30mm). Or the total thickness of less than 6.5 mm brake pads, please replace the brake pads.

Inspection for Brake Disc

Inspect the thickness of the brake disc regularly and replace the disc if the thickness is less than 3 mm.

Warning!

When use new brake discs or new brake pads at beginning, it should be lightly squeeze and hold the brake for several times at low speed (less than 20km/h), so as to generate appropriate braking friction.

Tire Inflation

Tire pressure should be checked and adjusted to the proper tire pressure levels before each ride. Tire pressure should be checked using an accurate gauge when the tires are cool. Always replace the valve stem cap when finished adjusting tire pressures.

Front tire: 225Kpa; Rear tire: 225Kpa

Warning!

Under-inflation is a common cause of tire damages and may result in severe tire cracking, tire tread separation, "blowout", or unexpected loss of bike control, causing serious injury or death.

Drive Chain Lubrication

Follow the manufacturer's instructions for the chain cleaner you are using; below are the general guidelines. Do not allow any of the lubricant to get on the brake pads.

1. Turn the wheel backwards slowly and spray the lubricant on the inside of the chain inks.
2. Turn the wheel backwards slowly and spray the lubricant on the outside of the chain links.
3. Let the vehicle stand for 30 minutes to allow the lubricant to penetrate the links rollers.

Warning!

Always wear safety goggles when lubricating the drive chain to prevent eye injuries. Never have the motor spinning the wheel. Turn the wheel only by hand. Failure to do so could result in serious injury. Never place your hand between the chain and sprockets. Work with the chain only in the middle between the two sprockets. Failure to do so could result in serious injury. Do not allow any of the lubricant to get on the brake discs or brake pads. If the brake rotors or brake pads are contaminated with lubricant, it will impair the bike's ability to stop. This could result in serious injury or death. Follow the manufacturer's instructions for the chain cleaner you are using; below are the general guidelines. Do not allow any of the lubricant to get on the brake pads.

Checking the Drive Chain

Move the drive chain up and down by hand, and ensure the tolerance within the range :

15mm -25mm

Adjusting the Drive Chain

Note: Adjust both sides equally.

1. Remove key from the key switch .
2. Loosen the rear axle nut on right side of the vehicle.
3. Loosen the (left and right) M6 jam nuts.
4. Turn the (left and right) M6 adjustment bolts 1/4 turn at a time until the chain adjustment is within specification.

5. Visually align the chain adjusting bolt scales left and right.
6. Tighten left and right jam nuts to secure the chain.
7. Tighten the axle nut on right side of vehicle. Torque 50-60N.m.
8. Test ride the vehicle.
9. Recheck the chain for proper adjustment after the test ride and readjust, if necessary.

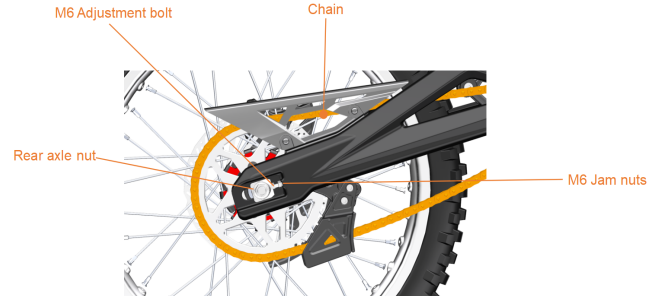

Adjusting Chain Guide

STING PRO installed the 48T stock sprocket.

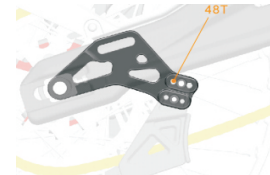

Maintenance of Gearbox Assembly and Controller

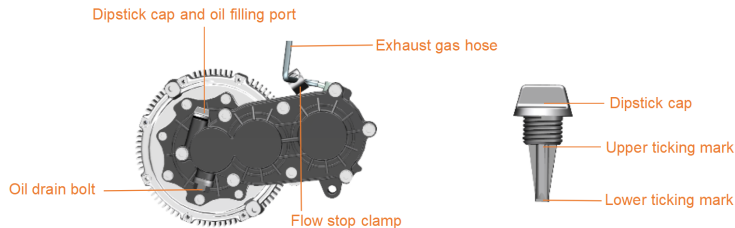

1. Regularly check whether the screws of the motor-gearbox assembly are loose and whether the gear oil is between the upper and lower ticking marks. It is strictly prohibited to ride when the gear oil is insufficient, because it will cause damage to the gearbox. After changing the gear oil during the run-in period for 300km, change the gear oil every 5000km (gear oil model: CL-5 85W/90, 70-90ml). Loosen the screw of dipstick cap on the gearbox, then loosen oil drain bolt, and the gear oil flows out through the oil drain hole. If no gear oil flows out, clean the magnetic core of the oil drain bolt, reinstall it into the gearbox, and add new gear oil with an amount of 70–90ml.
2. Regularly check whether the wiring of motor and controller is loose or insulated.
3. Regularly check whether the fuse is loose.
4. Do not ride the vehicle in deep water, otherwise, the motor may work incorrectly.
5. It's not recommended to use high-pressure washer to flush the motor and controller.
6. Please close the breather tube clamp during electric like transportation and open it before riding.

Adjustment of Battery Fixing Device

1. Remove the battery case cover.
2. Remove the battery fixing device.
3. Install the battery fixing device and make sure the fixing block well press on the battery handrail, then, well lock the battery fixing device.
4. Use the 8mm hex key to screw the fixing block travel adjusting bolt to well fix the battery with no movements. Screw the bolt clockwise to increase the travel, and screw the bolt counterclockwise to reduce the travel.



Caution

The travel of the adjusting bolt is 4.8mm. Usually, it's adjusted to well fix the battery when it's delivered from factory. But if you do think it's necessary to do the adjustment, please do it slowly while checking whether the battery is well fixed. If you adjust the travel aggressively without checking, may cause the battery handrail rubber damage or even battery upper cap damage due to the over pressure. If the battery handrail rubber damaged, please replace it in time.

Electrical diagram

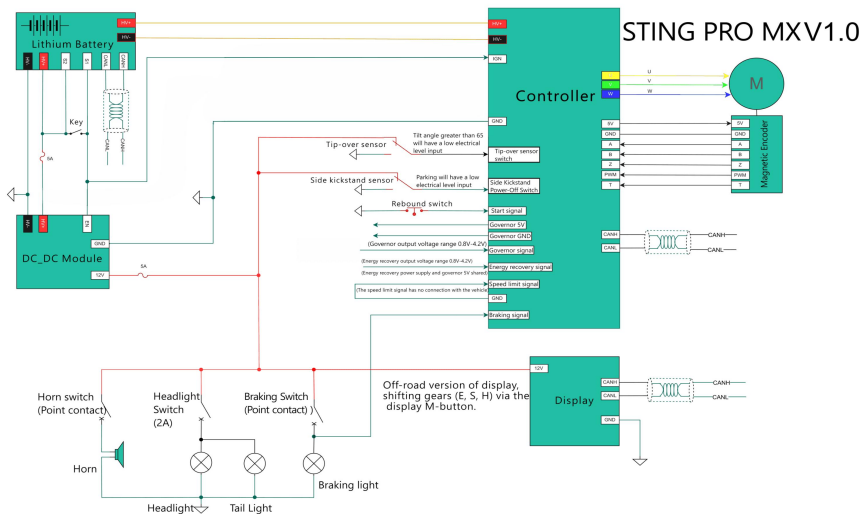

Technical Specification

ITEM	SPECIFICATION
Vehicle Dimension	1880×770×1088(mm)
Wheelbase	1250mm
N.W.	60kg(Battery Pack excluded)/76kg (Battery Pack included)
Max. Loading Ability	100kg
Min. Ground Clearance	280mm
Seat Height	840mm
Max. Gradeability	≥45°
Top Speed	20-25mph (restricted)
Nominal Power	1Kw (restricted)
Peak Power	1Kw (restricted)
Peak Motor Torque	16.5N.m (restricted)
Max. Torque on Rear Wheel	150N.m (restricted)
Battery Pack	72V 38.4Ah for Rated, and 84V 40Ah for Maximum
Max. Range	≥120Km@25KM/H
Charging Time	2-4h (Depends on charger)
Charger Input Voltage	AC110/230V-50/60Hz
Wheel Size	Fr.: 1.4×19; Rr.: 1.6×19
Tire Size	Fr.: 70/100-19; Rr.: 80/100-19
Fr. Suspension	Adjustable Hi-Performance Dual Spring Fork with 200mm±2 Travel
Rr. Suspension	Adjustable 85mm±2 Travel Diameter Reducing Spring Shock Absorber with Linkage
Brake Type	Fr. & Rr. Hydraulic Disc Brakes
Primary Transmission	Gearbox
Secondary Transmission	Chain (428-108)
Light	LED
Dash	TFT Colorful Display

Warranty Description

Dear customer:

For your rights and interests, please keep this owner's manual properly. Please inspect and test the electric bike when you purchase, and ask the salesman to offer valid invoice, warranty card, repair addresses, contact phone number, and other information.

Warranty differs from different editions, please check the warranty details when you purchase from the dealers.

If you find any problems while using the electric bike, you are entitled to get the after-sale service accord to the warranty policy from the dealer, where you ordered the electric bike, by providing the purchase invoice and warranty card.

If the any parts fail during the warranty period and cannot be used normally after maintenance, they will be replaced free of charge.

Caution: Any failures caused by abuse use, or DIY, it will enable the warranty to be invalid.

For any cross-border purchases, will cause the local distributor or dealers not fulfil the warranty, therefore, we strongly suggest to order from the authorized local dealers.

Maintenance Schedule

The scheduled maintenance must be performed in accordance with this chart to keep the Talaria Sting Pro electric bike in top running condition. The initial maintenance is vitally important and must not be neglected. Where time and mileage are listed, follow the interval that occurs first.

Item	Routine	Every Ride	1000KM 1 Month	6000KM 6Months	12000KM 12Months	18000KM 18Months	25000KM 24Months	32000KM 32Months
Brake (front and rear)	Check brake fluid level. Add brake fluid as necessary.	√	√	√	√	√	√	√
	Check thickness of the brake pads. Replace it as necessary.	√	√	√	√	√	√	√
	Check thickness of the brake discs. Replace it as necessary.	√	√	√	√	√	√	√
	Checked brake fluid leakage	√	√	√	√	√	√	√
	Check whether the brake is loose	√	√	√	√	√	√	√
	Replace brake fluid				√		√	√
	Check brake levers. Adjust or replace if necessary.	√	√	√	√	√	√	√
Wheels and Tires	Check tire pressure. See page 41. Correct if necessary.	√	√	√	√	√	√	√

Item	Routine	Every Ride	1000KM 1 Month	6000KM 6Months	12000KM 12Months	18000KM 18Months	25000KM 24Months	32000KM 32Months
Wheels and Tires	Check tread depth, and for damage. Replace if necessary.	√	√	√	√	√	√	√
	Check when the spokes is loose. Fasten if necessary.	√	√	√	√	√	√	√
	Check whether the front and rear wheels are aligned. Adjust if necessary.	√	√	√	√	√	√	√
	Check bearings for smooth operation. Replace if necessary.		√	√	√	√	√	√
Gearbox	See page 43. Adjust if necessary.	√	√	√	√	√	√	√
	Inspect belt for signs of damage or cracking. Replace if necessary.	√	√	√	√	√	√	√

Item	Routine	Every Ride	1000KM 1Month	6000KM 6Months	12000KM 12Months	18000KM 18Months	25000KM 24Months	32000KM 32Months
Driving Chain	Check driving chain tension. See page 57. Adjust if necessary.	√	√	√	√	√	√	√
	Driving chain clear and lubricating		√	√	√	√	√	√
Steering Bearings	Check for looseness.	√	√	√	√	√	√	√
	Repack with all-purpose grease.		√	√		√	√	√
Front Fork and Rear Shock Absorber (Please also refer to fork and shock absorber manual).	Check operation, Service/adjust/replace if necessary.	√	√	√	√	√	√	√
	Check oil leakage. Service/rebuild/replace if necessary.	√	√	√	√	√	√	√
Throttle	Check operation. Adjust or replace if necessary.	√	√	√	√	√	√	√
Side Kickstand	Check operation. Adjust or replace if necessary.	√	√	√	√	√	√	√
	Apply silicon grease lightly.		√	√	√	√	√	√

Item	Routine	Every Ride	1000KM 1 Month	6000KM 6Months	12000KM 12Months	18000KM 18Months	25000KM 24Months	32000KM 32Months
Motor	Check motor phase wire connections. Fasten if it's loose.	√	√	√	√	√	√	√
	Check magnetic coder. Fix if it's loose.	√	√	√	√	√	√	√
Heavy current cables	Check the heavy current cables for damages. Service/replace if necessary.	√	√	√	√	√	√	√
	Check the connections, Fasten if it's loose.	√	√	√	√	√	√	√
Fasteners	Check the fasteners' torque. Fasten if necessary.	√	√	√	√	√	√	√

Maintenance Guide

MAINTENANCE PERIOD	MAINTENANCE REQUIREMENTS	REMARKS
300KM or 1 month	Check the fasteners of the electric motorcycle (motor, wheels, brake, spokes, etc.) to make sure all the fasteners are tightly fastened. And check the tension of the chain to make sure it's in the proper tension range.	
After the first maintenance Each 1000KM or 3 months	Check the fastening status of the safety components of the entire vehicle (motor, wheels, brake, spokes, etc.) to make sure all the components are well fastened. Check the high-current circuit electrical components to make sure all the electrical components are in a good condition to ensure a safety riding. Check the tension of the chain to make sure it's in the proper tension range.	
2000KM or 6 months	Check the high-current circuit electrical components to make sure all the electrical components are in a good condition to ensure a safety riding. Check the brake oil level and brake pads to make sure it's sufficient enough to ensure the brakes work properly. Check the tension of the chain to make sure it's in the proper tension range.	

Maintenance Record Card

Maintenance Record Card			
Date	Odometer reading	Maintenance	Remarks

Customer Information Card

Basic Information	Model		
Owner's Name		Order Date	
SN			